

RENNICKS SIGN FIXING SYSTEMS



For further information please contact:

Rennicks (UK) Ltd
Stuart Road, Manor Park, Runcorn, Cheshire, WA7 1TS

Tel: 01928 579966 Fax: 01928 579965
Email: uksales@rennicks.com
Visit: www.rennicksuk.com

Whilst every care has been taken to ensure that the information included in this document was accurate at the time of printing, Rennicks UK Ltd/Mobile Traffic Solutions Ltd reserve the right to change product specifications at any time without prior notice. The photographs and colours reproduced in this publication are within the constraints of the printing process and are not to be used for matching purposes. All photographs are used for approximate representation only and may not show the actual products on offer. E&OE.

RUKHW001 / November 2011

Rennicks^{U.K.}
CLEARLY BETTER

Rennicks^{U.K.}
CLEARLY BETTER

QUALITY, INNOVATION AND RELIABILITY

THE DIFFERENCE IS CLEAR WITH RENNICKS

Rennicks provide a comprehensive range of extruded aluminium channel profiles and sign fixings to the road traffic and commercial sign industries. Our hardware range has evolved over 25 years to meet industry and customer needs and Rennicks continue to adapt to new requirements.

To assist the sign manufacturer in demonstrating structural conformity of road traffic signs to BS EN 12899-1, Rennicks provides **SignLoad** software approved by BSi for CE marking applications by calculation to the structural requirements of BS EN 12899-1 for sign plates. A declaration of conformity can be produced from **SignLoad** confirming the factors considered in the structural evaluation and provided to the client.

To determine the channel type and positions for the structural design the sign manufacturer selects the factors shown below and the substrate type.

SignLoad then provides the optimum Rennicks channel type and spacing for compliant and cost effective support using the least number of channels.

- sign dimensions
- basic wind pressure
- number of posts
- post centres / overhang
- mounting height

The basic wind pressure (wind loading class) is provided by the specifier for the installed location or selected from the National Annex in BS EN 12899-1, which provides recommendations on regional wind loads and proximity to the coast.



CONTENTS

Aluminium Clip System	4
Stainless Steel Clip System	6
Aluminium Uniclip System	7
Stainless Steel Banding System	8
Aluminium Offset Brackets	9
Aluminium Channel Systems	11
Interlocking Aluminium Channel System	12
Declaration of Conformity	15

This brochure displays our complete hardware range with easy cross-reference to our price list.

To place an order call:

01928 579966

Fax: 01928 579965 Email: uksales@rennicks.com



A member of The Association of Road Traffic Safety and Management (ARTSM) and an Associate Member of Local Authorities Sign Manufacturers Association (LASMA).

ALUMINIUM CLIP SYSTEM

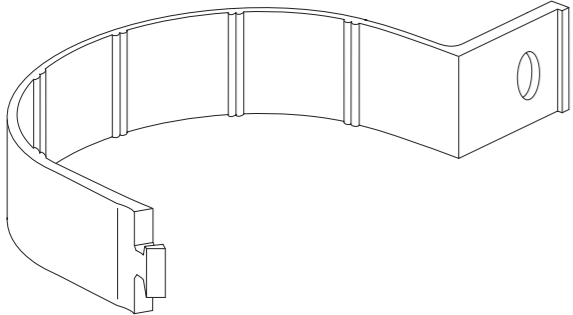
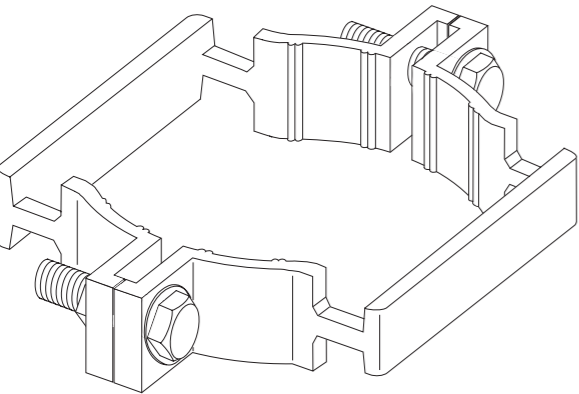
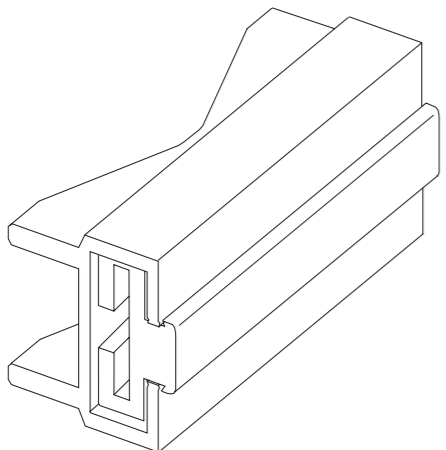
	DESCRIPTION	SIZE	CODE
<p>ALUMINIUM CHANNEL CLIPS FOR ROUND POSTS ANTI-ROTATIONAL 1 BOLT CLIP</p> 	<p>Twist in anti-rotational, single bolt design. Quick and easy to use. Supplied complete with one M8 x 38mm grade 18/8 stainless steel square head bolt, nut and washer.</p>	<p>76mm 89mm 114mm</p>	<p>CL076RO053 CL089RO053 CL114RO053</p>
<p>ALUMINIUM BACK TO BACK CLIPS</p> 	<p>Easy to use, cost effective, two component clip. Slide into channels, clips firmly grip post and channel during tightening of the bolts. Does not require standard clip fixing first. Supplied complete with two M8 x 35mm grade 18/8 stainless steel hexagon bolts, nuts and washers.</p>	<p>76mm 89mm 114mm</p>	<p>CL076BB077 CL089BB078 CL114BB080</p>
<p>ALUMINIUM BANDING CLIPS HEAVY DUTY UNIVERSAL</p> 	<p>Designed for heavy duty use with channelling. Anti-slide, self locking feature on tightening. Recommended for use with heavy signs on larger diameter posts. Equipped with plastic insert for easy assembly.</p>		<p>CL000BA102</p>

ALUMINIUM CLIP SYSTEM

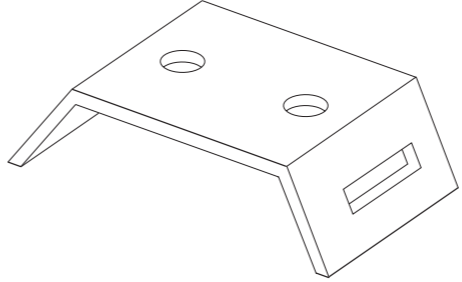
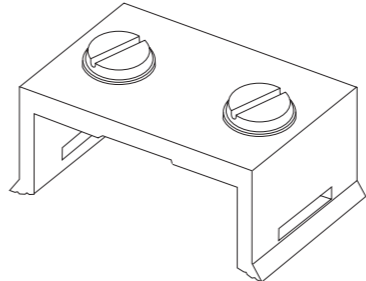
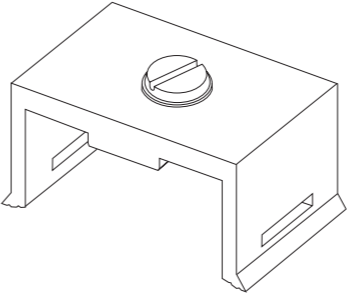
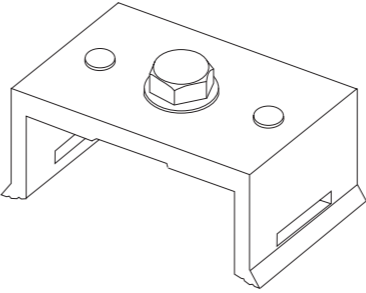
	DESCRIPTION	SIZE	CODE
<p>ALUMINIUM BANDING CLIPS Small 'C' Clip (2 holes)</p> 	<p>Designed for use with timeplates and small signs. Attach to sign using 2 x 4.8mm rivets.</p>		<p>CL000BA106</p>
<p>ALUMINIUM BANDING CLIPS 2 Bolt Large 'C' Clip</p> 	<p>Designed for use where channel is not required. Supplied complete with two M8 x 12mm grade 18/8 stainless steel panhead screws and nylon washers.</p>		<p>CL000BA103</p>
<p>ALUMINIUM BANDING CLIPS 1 Bolt Large 'C' Clip</p> 	<p>Designed for use with smaller regulatory, warning and timeplate signs. Supplied complete with one M8 x 12mm grade 18/8 stainless steel panhead screw and nylon washer.</p>		<p>CL000BA105</p>
<p>ALUMINIUM BANDING CLIPS 1 Bolt Large Channel Clip</p> 	<p>Designed for use with channelling, featuring special lugs to prevent swivelling once tightened. Supplied complete with one M8 x 12mm grade 18/8 stainless steel hexagon bolt, nut and washer.</p>		<p>CL000BA104</p>

STAINLESS STEEL CLIP SYSTEMS

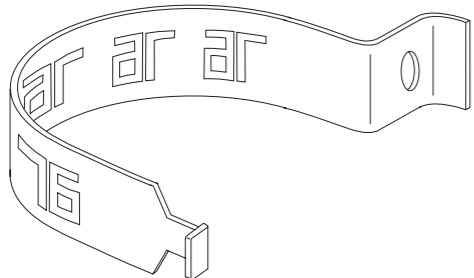
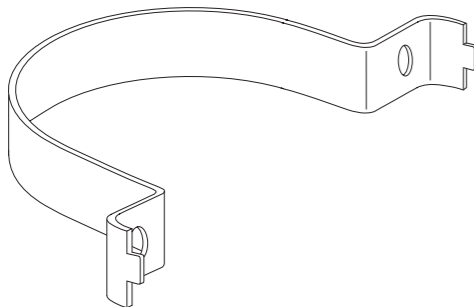
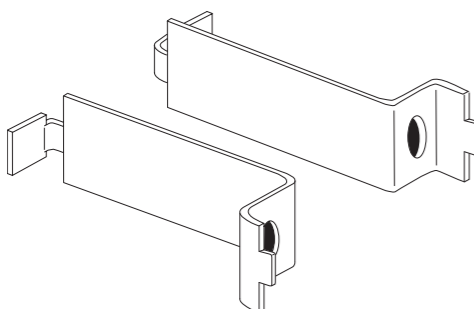
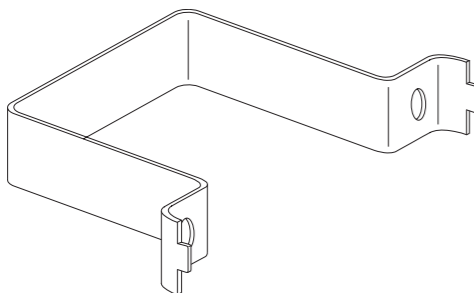
	DESCRIPTION	SIZE	CODE
<p>STAINLESS STEEL CHANNEL CLIPS FOR ROUND POSTS ANTI-ROTATIONAL 1 BOLT CLIP</p> 	<p>Anti-rotational stainless steel clips with embossed size stamped around outer circumference of clip. Complete with one M8 x 38mm square head bolt assembly.</p>	<p>60mm 76mm 89mm 114mm</p>	<p>CL060SS CL076SS CL089SS CL114SS</p>
<p>STAINLESS STEEL CHANNEL CLIPS FOR ROUND POSTS 2 BOLT CLIP</p> 	<p>Stainless steel clip for use with large diameter round posts. Supplied complete with two M8 x 38mm square head bolt assemblies. 140 and 168 clips are 2mm thick. 194, 219, 244 and 273 are 3mm thick</p>	<p>2mm x 50mm 2mm x 140mm 2mm x 168mm 3mm x 194mm 3mm x 219mm 3mm x 244mm 3mm x 273mm</p>	<p>CL050SS CL140SS CL168SS CL194SS CL219SS CL244SS CL273SS</p>
<p>STAINLESS STEEL BACK TO BACK CLIPS</p> 	<p>For attaching second sign with the same channel spacing to rear of first sign mounted using standard clips.</p>	<p>50mm 60mm 76mm 89mm 114mm 140mm 168mm 194mm 219mm 244mm 273mm</p>	<p>CL050SSBB CL060SSBB CL076SSBB CL089SSBB CL114SSBB CL140SSBB CL168SSBB CL194SSBB CL219SSBB CL244SSBB CL273SSBB</p>
<p>STAINLESS STEEL CHANNEL CLIPS FOR RECTANGULAR POSTS</p> 	<p>Range of rectangular and square post clips. Supplied complete with two off M8 x 38mm square head bolt assembly. Other sizes available on request.</p>	<p>50 x 50mm 80 x 40mm 80 x 80mm 100 x 50mm 120 x 60mm 120 x 80mm 150 x 100mm 200 x 100mm 250 x 150mm 300 x 200mm 400 x 200mm</p>	<p>CL050SS050 CL080SS040 CL080SS080 CL100SS050 CL120SS060 CL120SS080 CL150SS100 CL200SS100 CL250SS150 CL300SS200 CL400SS200</p>

ALUMINIUM UNICLIP SYSTEMS

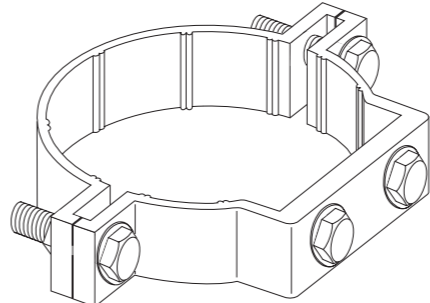
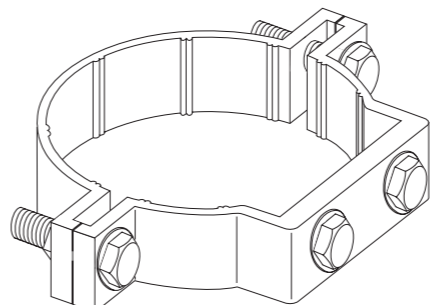
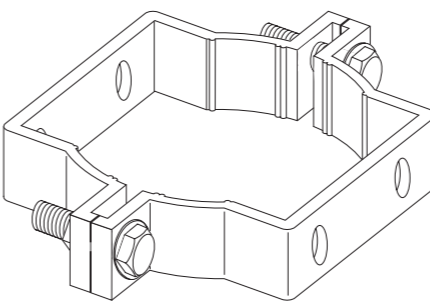
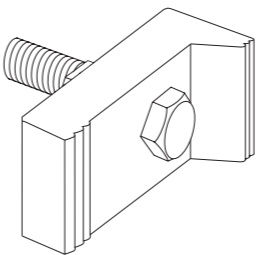
	DESCRIPTION	SIZE	CODE
<p>ALUMINIUM UNICLIPS - STANDARD</p> 	<p>Designed for use on signs without channel. Supplied complete with two grade 18/8 stainless steel M8 x 12mm bolts, nuts and nylon washers (panhead option) for fixing plate, and two grade 18/8 stainless steel M8 x 35mm bolts, nuts and washers for pole fixing.</p>	<p>76mm 89mm 114mm</p>	<p>CL076UN081 CL089UN089 CL114UN084</p>
<p>ALUMINIUM UNICLIPS - TAPPED & THREADED</p> 	<p>Designed for use on signs without channel. Supplied complete with two grade 18/8 stainless steel M8 x 12mm bolts and nylon washers (panhead option) for fixing plate, and two grade 18/8 stainless steel M8 x 35mm bolts, nuts and washers for pole fixing.</p>	<p>76mm</p>	<p>CL076UN086</p>
<p>ALUMINIUM UNICLIPS - BACK TO BACK</p> 	<p>Designed for use on signs without channel. Supplied complete with four grade 18/8 stainless steel M8 x 12mm bolts, nuts and nylon washers (panhead option) for fixing plate, and two grade 18/8 stainless steel M8 x 35mm bolts, nuts and washers for pole fixing.</p>	<p>76mm 89mm 114mm</p>	<p>CL076UN088 CL089UN089 CL114UN091</p>
<p>ALUMINIUM RSJ CLAMP</p> 	<p>Designed for use when mounting channelled signs or extruded aluminium plank sections onto 'I' beams. Supplied complete with one M8 x 38mm grade 18/8 stainless steel hexagon bolt, nut and washer.</p>		<p>CL000RS097</p>

STAINLESS STEEL BANDING SYSTEM

The Rennicks' Stainless Steel Banding System has been developed to meet all the requirements of the sign industry. Our uniquely practical, convenient and efficient dispenser accommodates two band widths

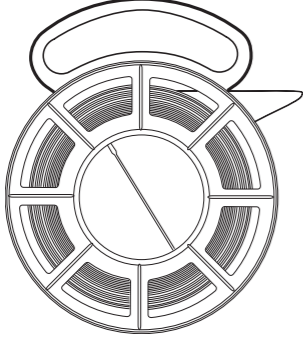
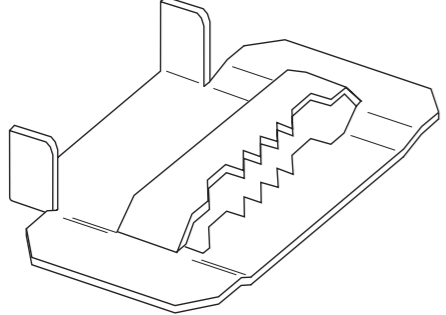
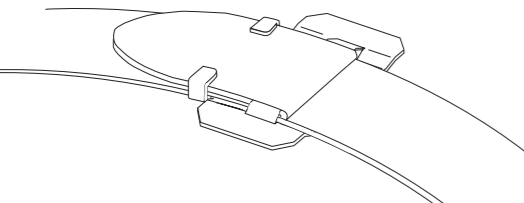
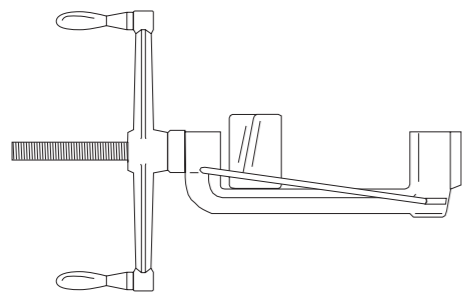
	DESCRIPTION	SIZE	CODE																												
<p>STANDARD BANDING</p> 	Grade 201 stainless steel banding supplied in a tough weatherproof plastic dispenser with convenient handle for efficient use.	13mm x 30.5m 19mm x 30.5m	SB13MM1 SB19MM1																												
<p>STANDARD BUCKLES</p> 	Grade 201 stainless steel buckles for use with stainless steel banding. Supplied in quantities of 100.	13mm 19mm	SB13MMB SB19MMB																												
<p>BUCKLE STRAPS WITH BANDING BUCKLE</p> 	Convenient prepared lengths of Grade 201 strap with spot welded buckles. Saves time on site with performance equal to conventional banding techniques. Supplied in quantities of 50.	<table border="1"> <thead> <tr> <th>Width (mm)</th> <th>Size</th> <th>Length (mm)</th> <th>Max Post Dia.</th> </tr> </thead> <tbody> <tr> <td>13</td> <td>1</td> <td>460</td> <td>76</td> </tr> <tr> <td>13</td> <td>2</td> <td>660</td> <td>150</td> </tr> <tr> <td>13</td> <td>3</td> <td>1120</td> <td>300</td> </tr> <tr> <td>19</td> <td>1</td> <td>460</td> <td>76</td> </tr> <tr> <td>19</td> <td>2</td> <td>660</td> <td>150</td> </tr> <tr> <td>19</td> <td>3</td> <td>1120</td> <td>300</td> </tr> </tbody> </table>	Width (mm)	Size	Length (mm)	Max Post Dia.	13	1	460	76	13	2	660	150	13	3	1120	300	19	1	460	76	19	2	660	150	19	3	1120	300	SBB130460B SBB130660B SBB131120B SBB190460B SBB190660B SBB191120B
Width (mm)	Size	Length (mm)	Max Post Dia.																												
13	1	460	76																												
13	2	660	150																												
13	3	1120	300																												
19	1	460	76																												
19	2	660	150																												
19	3	1120	300																												
<p>BANDING SYSTEM ACCESSORIES - BANDING TOOL</p> 	Banding Tool for tensioning stainless steel banding		SBBAND																												

ALUMINIUM OFFSET BRACKETS FOR END MOUNTING

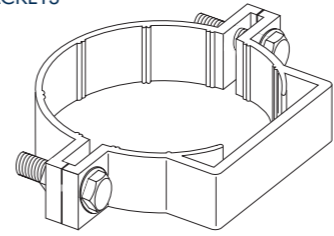
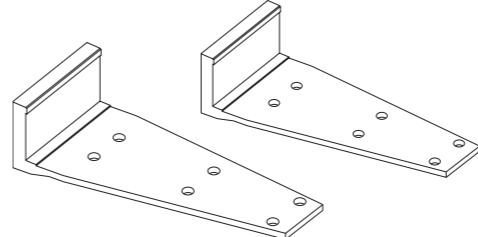
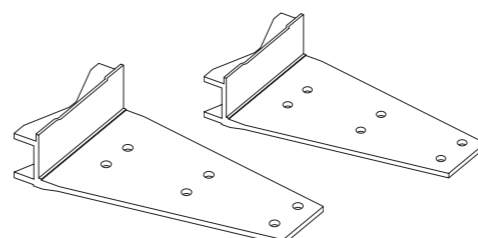
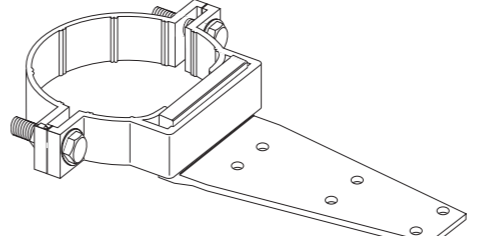
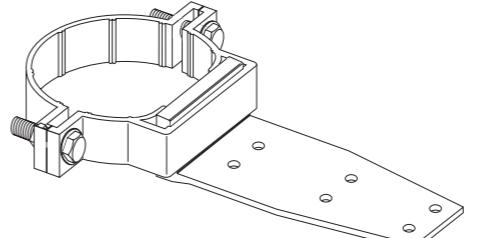
	DESCRIPTION	SIZE	CODE
<p>ANTI-ROTATIONAL UNICLIPS TO FIT SMALL AND LARGE OFFSET BRACKETS</p> 	For use with offset bracket and round post.	76mm 89mm 114mm	CL076UN095 CL089UN095 CL114UN095
<p>OFFSET BRACKET - CLIP TYPE</p> 	Suitable for all types of fingerpost and flag-type signs with Anti-Rotational Uniclips as above.	Small with holes Large with holes Small no holes Large no holes	BK000CS01H BK000CL02H BK000CS01 BK000CL02
<p>OFFSET BRACKET - BANDING TYPE</p> 	Suitable for all types of fingerpost and flag-type signs. Designed for use with our stainless steel banding.	Small with holes Large with holes Small no holes Large no holes	BK000BS03H BK000BL04H BK000BS03 BK000BL04
<p>OFFSET BRACKET WITH ANTI-ROTATIONAL UNICLIP</p> 	Suitable for small fingerpost and flag-type signs, with Small 'T' Section (ST3), supplied complete with special Anti-Rotational Unclip designed to hug the post. Supplied complete with two M8 x 35mm grade 18/8 stainless steel hexagon bolts, nuts and washers.	76mm	BK076CS05
<p>OFFSET BRACKET WITH ANTI-ROTATIONAL UNICLIP</p> 	Suitable for all types of fingerpost and flag-type signs manufactured with Large Tee Section (LT3). Complete with special Anti-Rotational Unclip. Supplied complete with two M8 x 35mm grade 18/8 stainless steel hexagon bolts, nuts and washers.	76mm 89mm 114mm	BK076CL06 BK089CL02 BK114CL09

ALUMINIUM OFFSET BRACKETS COMPLETE WITH 'T' SECTION

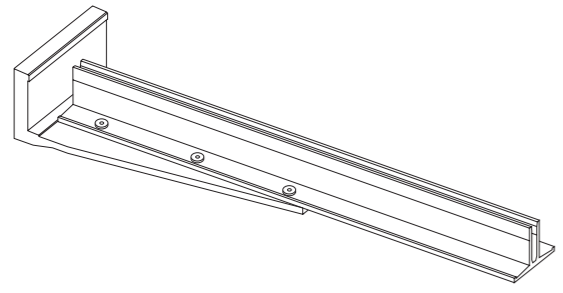
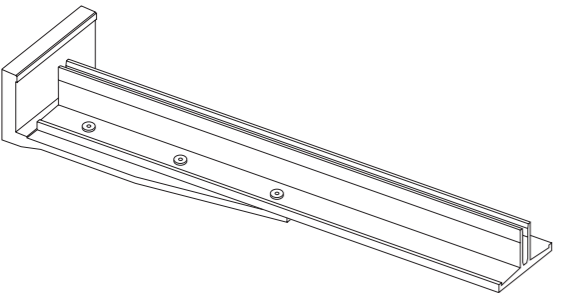
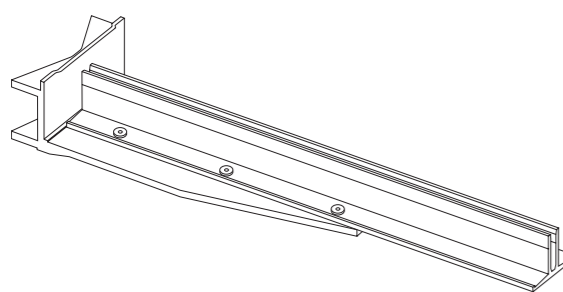
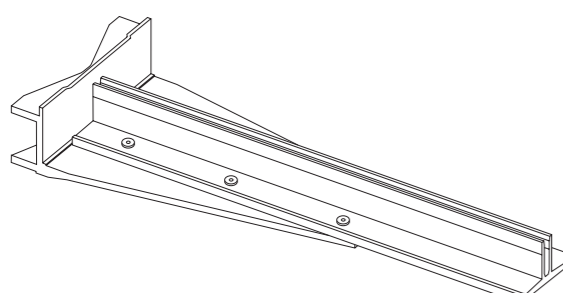
	DESCRIPTION	SIZE	CODE
<p>OFFSET BRACKET WITH SMALL RIVETED 'T' SECTION FOR USE WITH UNICLIPS</p> 	<p>Pre-assembled offset brackets with small 'T' section attached using self-piercing rivets. Available in popular lengths for off-the-shelf fingerpost and flag-type signs. Use with anti-rotational unclips UCS 076, UCS 089, UCS 102 and UCS 114.</p>	<p>150mm 300mm 375mm 450mm</p> <p>Other sizes available to suit your requirements.</p>	<p>BK150CS10 BK300CS12 BK375CS13 BK450CS14</p>
<p>OFFSET BRACKET WITH LARGE RIVETED 'T' SECTION FOR USE WITH UNICLIPS</p> 	<p>Pre-assembled offset brackets with large 'T' section as above.</p>	<p>600mm</p> <p>Other sizes available to suit your requirements.</p>	<p>BK600CL22</p>
<p>OFFSET BRACKET WITH SMALL RIVETED 'T' SECTION FOR USE WITH BANDING</p> 	<p>Pre-assembled with small 'T' section for banding.</p>	<p>300mm 450mm</p> <p>Other sizes available to suit your requirements</p>	<p>BK300BS17 BK450BS19</p>
<p>OFFSET BRACKET WITH LARGE RIVETED 'T' SECTION FOR USE WITH BANDING</p> 	<p>As above with large 'T' section for use with banding.</p>	<p>450mm 525mm 600mm</p> <p>Other sizes available to suit your requirements.</p>	<p>BK450BL28 BK525BL29 BK600BL30</p>

ALUMINIUM CHANNEL SYSTEMS

Rennicks channels are designed for use with self-piercing riveting systems. To ensure Road Traffic Signs comply with the clients structural requirements, reference should be made to the Rennicks SignLoad CD and information detailed at the front of this brochure.

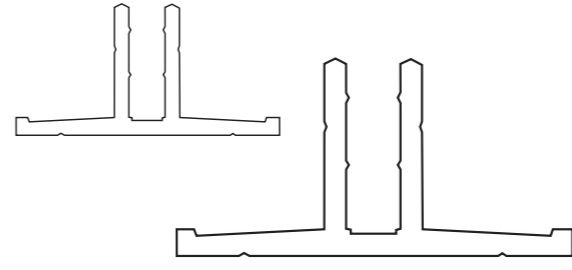
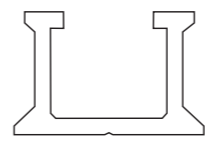
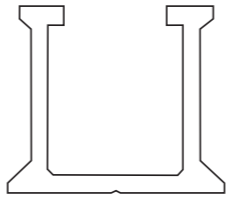
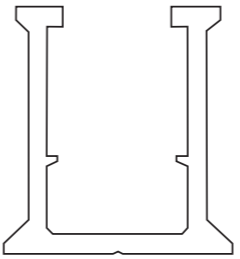
	DESCRIPTION	SIZE	CODE
<p>CHANNEL - 'T' SECTION</p> 	<p>Designed to suit all types of fingerpost signs. Used in conjunction with our offset brackets. Small 'T' suitable for signs up to 500mm wide. Large 'T' for signs up to 1.5m wide.</p>	<p>Small 'T' 3m Mill Large 'T' 3m Mill</p> <p>Small 'T' 3m Painted Large 'T' 3m Painted</p> <p>Small 'T' 3m Black Large 'T' 3m Black</p>	<p>CH3MS12 CH3ML13</p> <p>CH3PS12 CH3PL13</p> <p>CH3BS12 CH3BL13</p>
<p>CHANNEL - SMALL</p> 	<p>Designed for use with smaller signs and compatible with self-piercing riveting systems.</p>	<p>3m Mill 5m Mill 3m Painted 5m Painted 5m Black</p>	<p>CH3MS01 CH5MS01 CH3PS01 CH5PS01 CH5BS01</p>
<p>CHANNEL - SMALL MEDIUM</p> 	<p>Also suitable for use with self-piercing riveting systems.</p>	<p>3m Mill 3m Painted</p>	<p>CH3MS02 CH3PS02</p>
<p>CHANNEL - MEDIUM</p> 	<p>Also suitable for use with self-piercing riveting systems.</p>	<p>3m Mill 5m Mill 3m Painted 5m Painted 5m Black</p>	<p>CH3MM03 CH5MM03 CH3PM03 CH5PM03 CH5BM03</p>

INTERLOCKING ALUMINIUM CHANNEL SYSTEM

The Rennicks Interlocking and Side Lock Channels offer significant cost savings over other channel combinations and require less fixing clips, thereby reducing sign erection times and further reducing the overall erected sign assembly costs as well.

The reduction in weight and smaller cross section area of the Side Lock Channels has not resulted in a weak channel, the combination of Interlocking Channel and Side Lock Channels together offer significant strength and support to the sign assembly. This is due to the unique designs which, when combined together have a larger surface contact area between the channels.

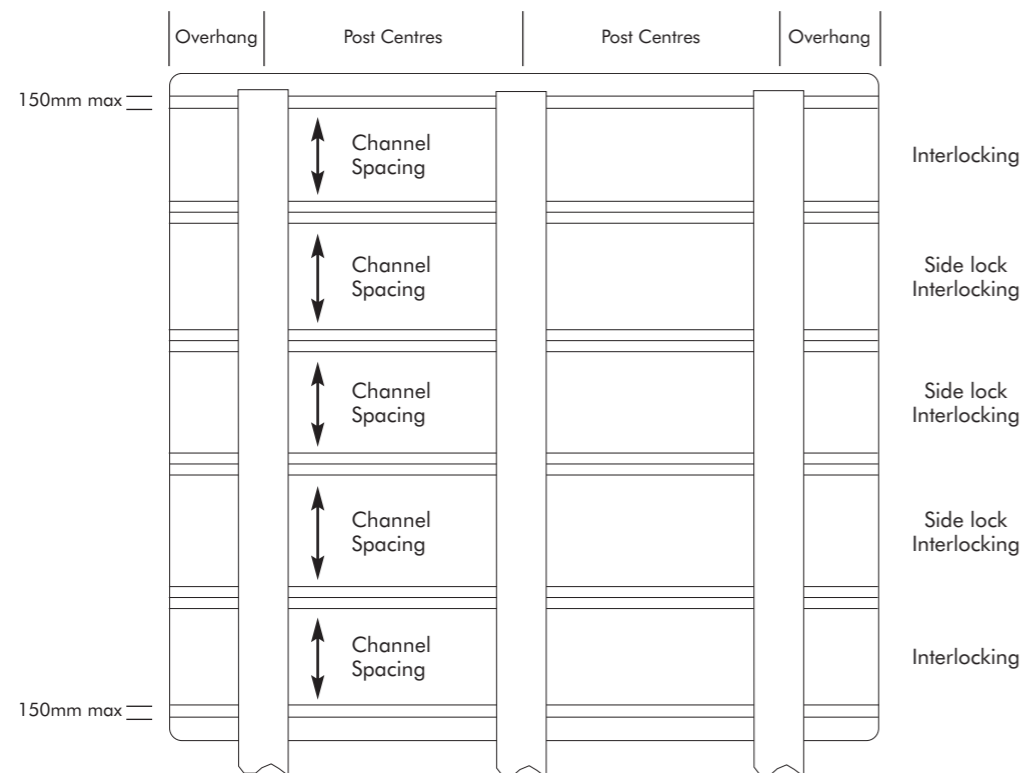
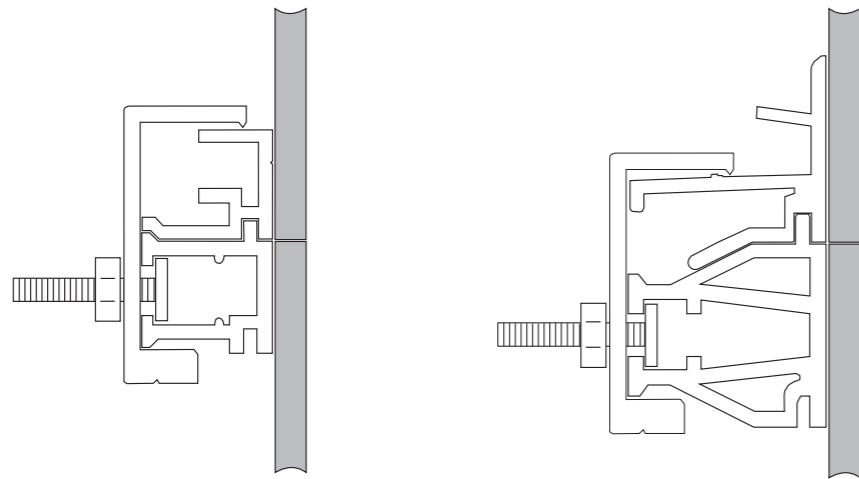

INTERLOCKING ALUMINIUM CHANNEL SYSTEM

	DESCRIPTION	SIZE	CODE
<p>CHANNEL - INTERLOCKING MEDIUM</p>	Interlocking medium channel with light shield provided by the interlocking design. Extrusion designed to be mated with itself or medium side lock channel.	5m Mill 5m Painted 5m Black	CH5MM07 CH5PM07 CH5BM07
<p>CHANNEL - MEDIUM SIDE-LOCK</p>	Designed for use with medium interlocking channel. This unique design offers savings through reduced channel cost, reduction in clip usage and reduced erection times.	5m Painted	CM5PM20
<p>CHANNEL - LARGE INTERLOCKING</p>	Interlocking large channel 38mm high with light shield provided by the interlocking design. Extrusion designed to be mated with itself or large side lock channel.	5m Mill 5m Black 5m Painted	CH5ML08 CH5BL08 CH5PL08
<p>CHANNEL - LARGE SIDE LOCK</p>	Unique design for use with large interlocking channel offering savings through reduced channel cost, reduction in clip usage and reduced erection times.	5m Painted 7m Mill 7m Painted	CH5PL20 CH7ML20 CH7PL20
<p>CHANNEL - LIGHT HEAVY - LARGE</p>	Interlocking large channel 35mm high with light shield provided by the interlocking design. Extrusion designed to be mated with itself.	5m Painted	CH5PL08N

ALUMINIUM CHANNEL SYSTEMS

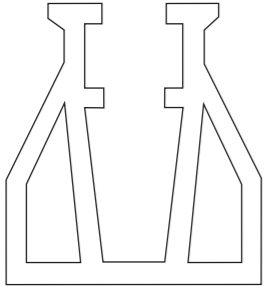
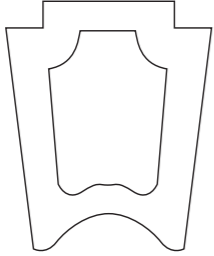
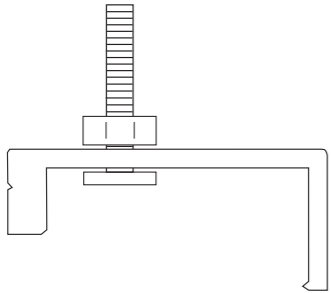
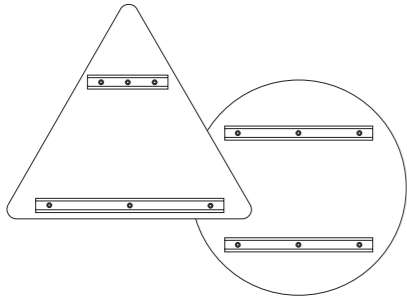
	DESCRIPTION	SIZE	CODE
<p>CHANNEL - LARGE SELF PIERCE</p> 	<p>38mm high designed for use where interlocking channel is not required.</p>	<p>5m Mill 7m Mill 5m Painted 7m Painted</p>	<p>CH5ML09 CH7ML09 CM5PL09 CH7PL09</p>
<p>JOINING CHANNEL</p> 	<p>Joining channel to be used in 500mm lengths (250mm either side of section joint) riveted inside ends of large channels to strengthen structure during installation. Suitable for Large, Large interlocking and Light heavy channel designs.</p>	<p>3m</p>	<p>CH3ML10N</p>
<p>UNIVERSAL BUTTING CLAMP FOR ALL CHANNELS</p> 	<p>Designed to secure abutting plates of channelled signs together. Complete with stainless steel hexagon bolts, nuts and washers.</p>		<p>CL000BCUNIA</p>
<p>CHANNELLED BLANKS</p> 	<p>Channelled blanks manufactured from 3mm aluminium or aluminium composite sheet.</p>	<p>300mm Circle 450mm Circle 600mm Circle 750mm Circle 900mm Circle 1200mm Circle 600mm Triangle 750mm Triangle 900mm Triangle 1200mm Triangle</p> <p>Other sizes available on request</p>	<p>CP0300 CP0450 CP0600 CP0750 CP0900C CP1200C CP0600T CP0750T CP0900T CP1200T</p>

DECLARATION OF CONFORMITY FOR CHANNEL AND SIGN FIXINGS

Supplier; Rennicks (UK) Ltd.

Intended use: Components for signs manufactured to BS EN 12899-1; 2007; Part 1 Fixed signs.

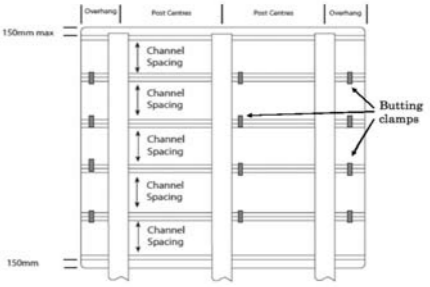
PRODUCT	FIXED VERTICAL TRAFFIC SIGNS
<p>Aluminium channel sections providing support to rear of signs</p> <p>Attached to substrate by sign manufacturer during sign manufacture.</p>	<p>5.3.1 Wind actions; Verification of performance by calculation using v2.37 (and above) SignLoad software. The wind loading class is provided by the specifier or selected from table NA2 in BS EN 12899-1;2007 National Annex for the signs location, and its proximity to the coast.</p> <p>We declare the design of the aluminium extrusions supplied by Rennicks (UK) Ltd., are of the same dimensions and alloy type as those included in SignLoad v2.37 (and above) Traffic sign structural calculation model.</p> <p>Conformity of the sign face to the structural requirements of BS EN 12899-1; 2007 is the responsibility of the sign manufacturer who determines certain factors in addition to information required from the specifier which includes; Sign dimensions, basic wind pressure, number of posts and centres / overhang and mounting height.</p> <p>Other classes are already set to the values recommended in the National Annex: 5.4.1 Temporary deflection Table 11 Bending TDB4 (or TDB5 for passively safe posts). 5.4.1 Temporary deflection Table 12 Torsion TDT4 (for signs on a single support) 5.3.2 Dynamic load from snow clearance DSL0 (no snow loading). 5.3.3 Point load PL3 (500 N) 5.4.2 Permanent deflection Pass 5.2 Partial safety factors PAF1</p> <p>7.1.2 Colour. Aluminium channel sections are available painted Aircraft Grey (BS 361C No. 693), Black RAL 9005 or aluminium mill finish.</p>
<p>For attaching signs to supports</p> <p>Aluminium Products; Channel Clips Banding Clips Uniclips RSJ Clamps Offset Brackets Butting Clamps</p> <p>Stainless Steel Products; Channel Clips Banding Coils Banding Buckles Buckle Straps</p>	<p>7.1.2 Colour. Aluminium products are finished with dulled self colour surface. Stainless Steel products are finished with self colour surface.</p> <p>7.1.7 Surface protection Class SP2; Inherent surface protection provided in aluminium and stainless steel products.</p> <p>7.1.14 Fixings; The products are designed to fit the supports to provide resistance to sliding and rotation.</p>
<p>Sign Installation</p>	<p>Rennicks sign channels are designed to be used with aluminium or stainless steel fixing systems of the generic M8 square head bolt design. Other propriety specialist clip systems may not be suitable.</p> <p>During installation appropriately sized channel clips should be attached at each point on a channel, designed to accept a clip, square head bolt, nut and washer, crosses a support. The washer should be placed between the nut and clip and the nut should be firmly tightened to secure the clip to the sign and support.</p> <p>Universal butting clamps are an integral part of the complete installation and should be fitted during installation across abutting sign sections to clamp together securely. Failure to fit butting clamps may result in sign failure or gaps appearing between sections as a result of post flexing.</p> <p>Stainless Steel banding is suitable for attaching small signs to irregular support sizes or shapes such as lamp columns. In all other situations the appropriate size clip should be used.</p> 

Mobile Traffic Solutions Ltd (MTS)

The sign of Intelligence

MTS is part of the Rennicks Group (head office based in Dublin), which has over a quarter of a century of experience in developing and producing state of the art traffic sign technology. At MTS we understand that information is power and nowhere is this truer than on the UK's busy roads where drivers have to take in a huge amount of information, often in a short space of time. That's why we have developed some of the most sophisticated portable variable message signs available.

At MTS, we are proud of the friendly and efficient service we offer to our clients, a service that has allowed us to establish special relationships with them which we value.

With our head office in Lingfield, Surrey and other depots nationwide, we can service our customers wherever they may be within the UK.



www.ukmts.com

